

Junction prior to cladding around window head

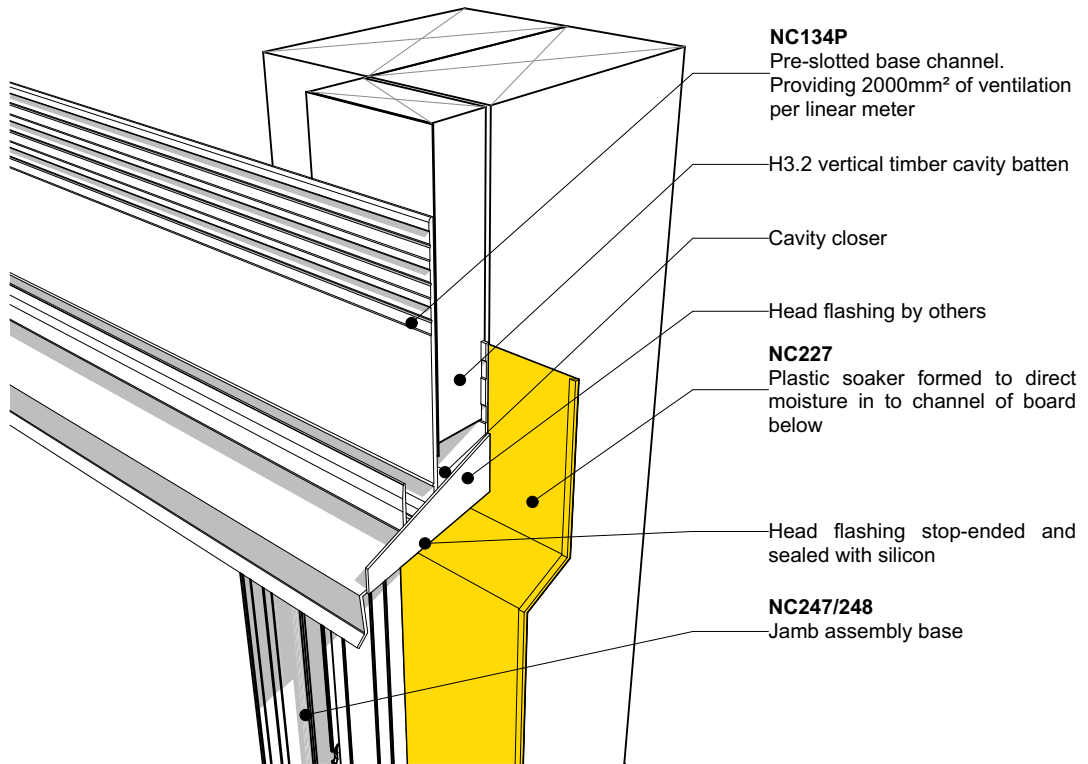

Junction after cladding around window head

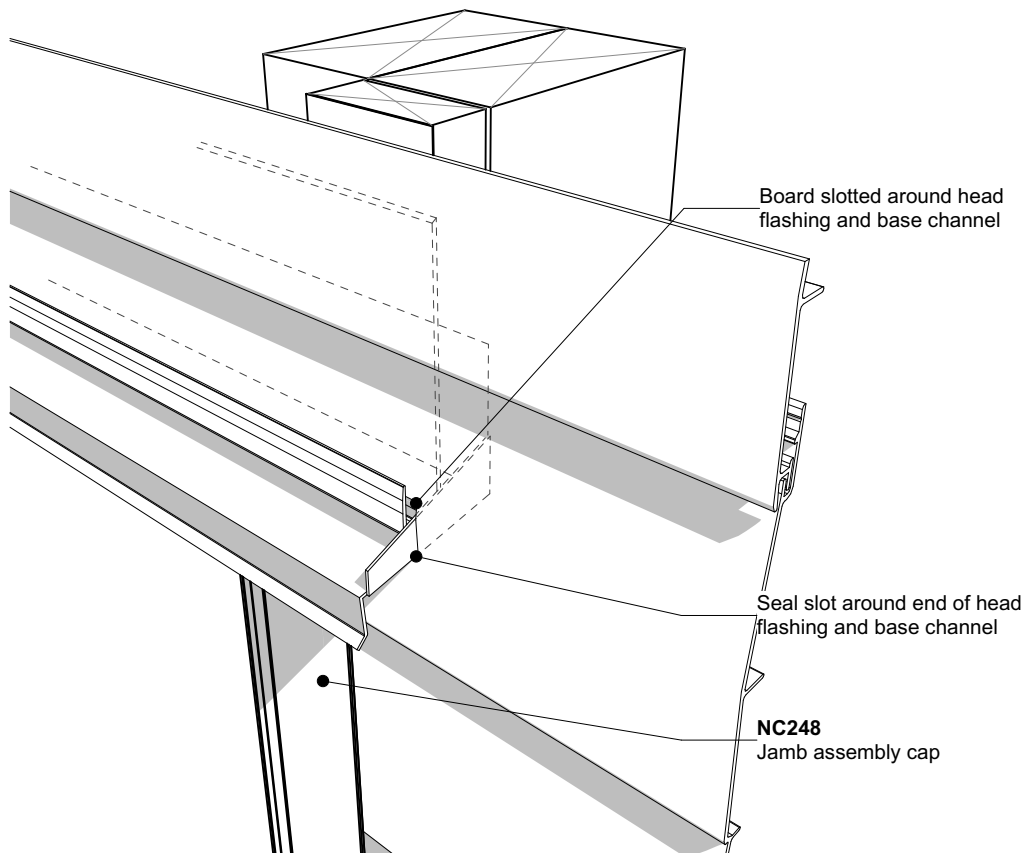

Nu-Wall cladding horizontal on cavity
Typical head flashing end detail

NW-HOC-020.02

Drawn by: Nu-Wall Date: 20/9/22

Checked by: RL, GT Scale: NTS

© 2021 copyright in this document is the property of Nu-Wall Aluminium Cladding Limited. All rights reserved. Nu-Wall is a registered trademark of Aluminium Product Brands NZ Limited